

**No. AH/RAH** Crank blades for plastic

**Plastic** **AH**/This is a set of crank shaped blade for plastic. It is effective when there are obstructions or the gate is narrow.  
**RAH**/This is a reverse bevel of AH type used when installing the main units face-to-face.

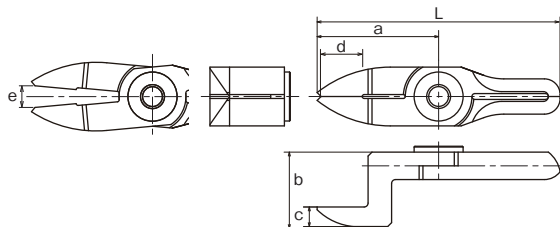

Model No.	Size (mm)						Weight (g)	Material	Applicable models	EDP No.
	a	b	c	d: Effective Length	e: Blade opening	L				
<b>NY05AH</b>	31	19	5	10.5	5.5	62	37	Special alloy steel	GT-NY05(-4) / NF05	360555
<b>NY05RAH</b>	30	12	5	10.5	5	61	31	Special alloy steel	GT-NY05R(-4) / NF05	360557
<b>NY10AH</b>	33	20	5	12	8	66	43	Special alloy steel	GT-NY10(-4) / NY10G(-4) / NF10 / NY10S	360565
<b>NY10RAH</b>	32	12.2	5	12	7	65	36	Special alloy steel	GT-NY10R(-4) / NY10GR(-4) / NF10 / NY10S	360567
<b>NY15AH</b>	38	21.5	5.5	13	11	76	63	Special alloy steel	GT-NY15(-4) / NF15	360575
<b>NY15RAH</b>	35	13.2	5.5	13	9	73	52	Special alloy steel	GT-NY15R(-4) / NF15	360577
<b>NY25AH</b>	46	24	6	17	13	92	110	Special alloy steel	GT-NY25(-6) / NY25S	360586
<b>NY25RAH</b>	42	16	6	16	12	88	89	Special alloy steel	GT-NY25R(-6) / NY25S	360588

>> For guidance on cutting capability, see P30 of the technical material.

**No. BJ/RBJ** Straight blades for metals

**Metal** **BJ**/This is a set of vertical blades with an unbeveled cutting edge for metal.  
**RBJ**/This is a reverse bevel of BJ type.

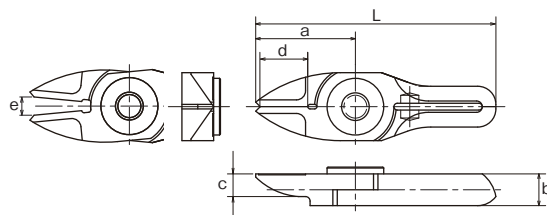

Model No.	Size (mm)						Weight (g)	Material	Applicable models	EDP No.
	a	b	c	d: Effective Length	e: Blade opening	L				
<b>NY05BJ</b>	22	7	5	10.5	4	53	22	Special alloy steel	GT-NY05(-4) / NF05	360558
<b>NY05RBJ</b>	22	7	5	10.5	4	53	22	Special alloy steel	GT-NY05R(-4) / NF05	360559

>> For guidance on cutting capability, see P30 of the technical material.

**No. GT-NT03/05/10/20** Sliding Air Nippers Vertical-type

- Blade opening is adjustable, and fine adjustments are easy to make after mounting the nippers, ensuring clean, unblemished cut surfaces.
- Blade can be installed either with the cutting edge outside or inside.

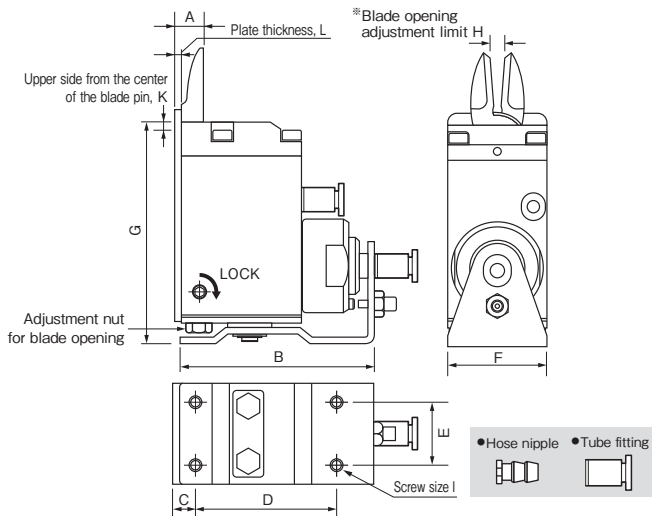

**Reference**

Capacity $\phi$ (mm) Soft Plastic Hard Plastic	Model No.	Size (mm)										Air Consumption (cni / str.)	Weight (g)	Slide Distance (mm)	Hose Port	EDP No.
		A	B	C	D	E	F	G	H	I	J					
1.5 1.0	<b>GT-NT03</b>											27	178	Pull 0~3	W/hose nipple	360601
1.5 1.0	<b>GT-NT03R</b>											27	178	Push 0~3	Hose I.D $\phi$ 2.5 mm	360611
1.5 1.0	<b>GT-NT03-4</b>	9	62	7	43	14	19	68.1	1.5~3	M3	2 5	27	178	Pull 0~3	W/tube fitting	360621
1.5 1.0	<b>GT-NT03R-4</b>											27	178	Push 0~3	Hose I.D $\phi$ 2.5×O.D. $\phi$ 4 mm	360631
2.5 1.5	<b>GT-NT05</b>											47	325	Pull 0~3	W/hose nipple	360602
2.5 1.5	<b>GT-NT05R</b>											47	325	Push 0~3	Hose I.D $\phi$ 2.5 mm	360612
2.5 1.5	<b>GT-NT05-4</b>	9	64	7	45	20	32	71.1	3~6	M4	2 5	47	325	Pull 0~3	W/tube fitting	360622
2.5 1.5	<b>GT-NT05R-4</b>											47	325	Push 0~3	Hose I.D $\phi$ 2.5×O.D. $\phi$ 4 mm	360632
3.5 2.3	<b>GT-NT10</b>											82	515	Pull 0~3	W/hose nipple	360603
3.5 2.3	<b>GT-NT10R</b>											82	515	Push 0~3	Hose I.D $\phi$ 2.5 mm	360613
3.5 2.3	<b>GT-NT10-6</b>	11	73	8	53	24	38	88.1	4~7	M4	2 5	82	515	Pull 0~3	W/tube fitting	360623
3.5 2.3	<b>GT-NT10R-6</b>											82	515	Push 0~3	Hose I.D $\phi$ 4×O.D. $\phi$ 6 mm	360633
5.0 3.4	<b>GT-NT20</b>											203	930	Pull 0~8	W/hose nipple	360604
5.0 3.4	<b>GT-NT20R</b>											203	930	Push 0~8	Hose I.D $\phi$ 4 mm	360614
5.0 3.4	<b>GT-NT20-6</b>	14	103	10	80	28	44	102.1	4.5~9	M5	2 6	203	930	Pull 0~8	W/tube fitting	360624
5.0 3.4	<b>GT-NT20R-6</b>											203	930	Push 0~8	Hose I.D $\phi$ 4×O.D. $\phi$ 6 mm	360634

※Capacity indication shows the reference value when a standard blade is mounted. Values vary depending on the blade shapes and type of cut objects.

※Blade opening adjustment limit (H) is the dimension adjusted for standard blade (AJ type) . ※Air Pressure:~0.4~0.5MPa (NT20 type: 0.5~0.6)

※Blades are optional. Note that a forward or a backward-facing blades are respectively available.